

BOSE

Panaray® MB4 4x Endfire Bass Array

General Description

The Panaray MB4 modular bass loudspeaker can be used in conjunction with the MB4 4x Endfire bass array bracket and the Panaray system digital controller to create directional bass as opposed to traditional omnidirectional dispersion.

The MB4 4x Endfire bass array provides a front-to-back SPL difference of up to 15dB. This allows the bass energy to be directed to areas of the installation where it is needed, while keeping the energy away from potential problem areas.

The 4x Endfire array bracket accommodates four MB4 modular bass loudspeakers which are spaced 29.0" (73.6 cm) apart, center-to-center. The Panaray system digital controller provides the speaker equalization as well as the delay, which is stored in a single preset. The result is a single Endfire bass array where the bass energy is fired out the front with 120° dispersion.

The preset in the Panaray controller is perfectly matched for use with the 4x Endfire bass array bracket, eliminating the need to calculate proper delay times and spacing to achieve this type of bass array.

MB4 4x Endfire Bass Array

Qty	Description
2	4x Endfire bass array Bracket (top and bottom)
1	Panaray system digital controller
4	MB4 modular bass loudspeaker

Technical Information

Frequency Range

40Hz to 300Hz ± 3 dB

Maximum Acoustic Output¹

122dB-SPL @ 1 m (pink noise)
(all units)

Long-Term Power Handling²

200W continuous (each unit). Total power of system is 800W (4 x 200W)

Impedance

8 Ω nominal (each unit)

Mechanical Specifications

Dimensions: 18.1"D x 10.2"W x 26.7"H
(46 cm x 25.9 cm x 67.8 cm)
(each unit)

Weight: 45 lb (20 kg) (each unit)

Connectors: Two (2) parallel-wired NL4 connectors (each unit)

Enclosure construction: High-density MultiFiber multi-layer wood particle panel with high-impact foamed polypropylene end caps

Available colors: White and Black

Additional Information

Spacing: 29.0" (73.6 cm)

MB4 4x Endfire Horizontal and Vertical Octave-Band Polar Data

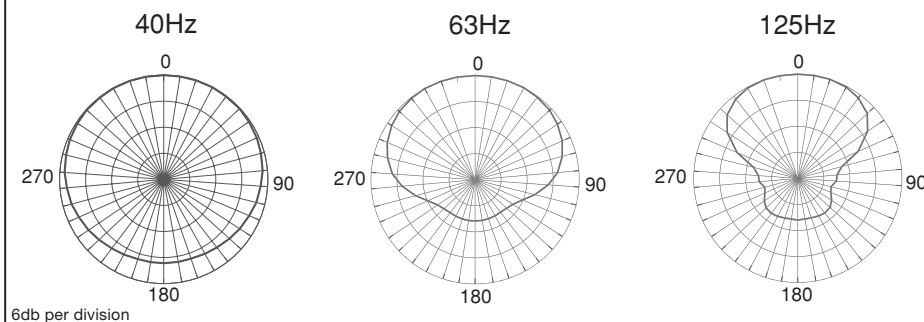

¹Band-limited pink noise is applied to the MB4 speaker and amplified to a level at the loudspeaker terminals corresponding to the long-term rated power handling of the speaker. The average sound pressure level (dB-SPL) is measured at 1 meter from the speaker in an anechoic environment.

²Band-limited noise, meeting the IEC Standard #268-5 is applied to the MB4 speaker and amplified to a level at the loudspeaker terminals corresponding to the power handling of the loudspeaker. The loudspeaker must show no visible damage or measurable loss of performance after 100 hours of continuous testing.

System Configurations

MB4 2x Endfire bass array

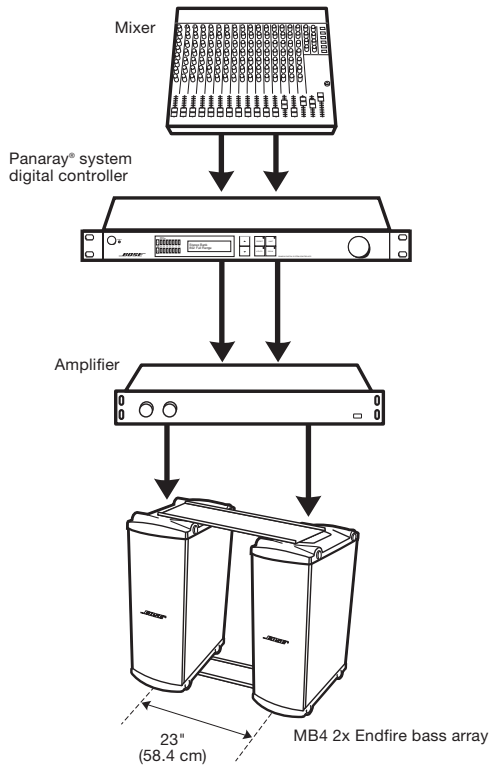

MB4 4x Endfire bass array

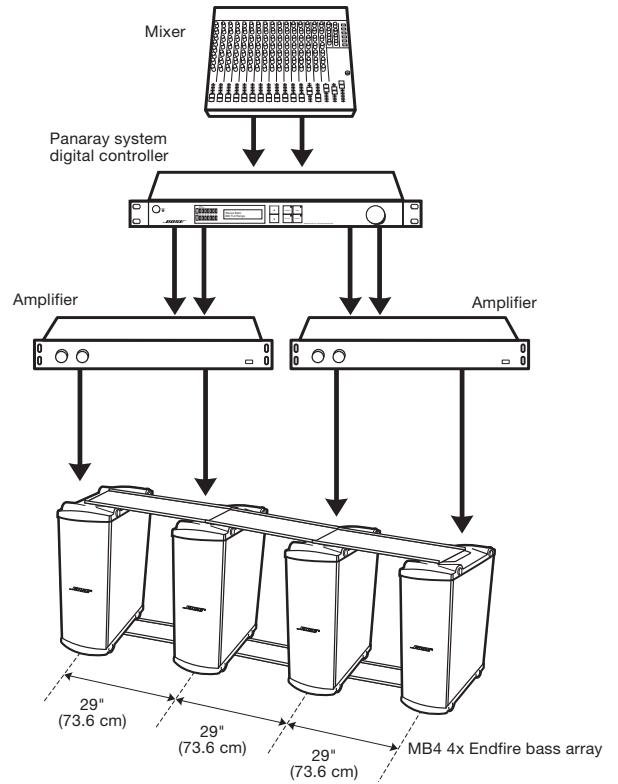

MB4 2x Broadside bass array

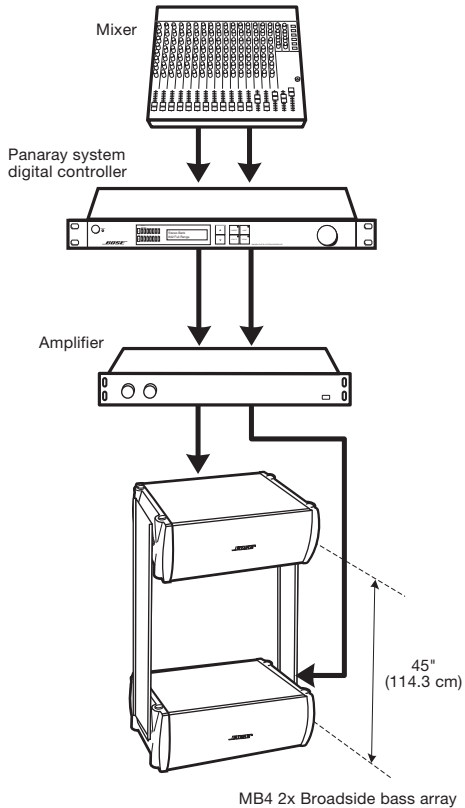

BOSE
Better sound through research.

©2001 Bose Corporation, The Mountain
Framingham, MA 01701-9168
261285 AM Rev.00 PC028151 JN20369
Preliminary